

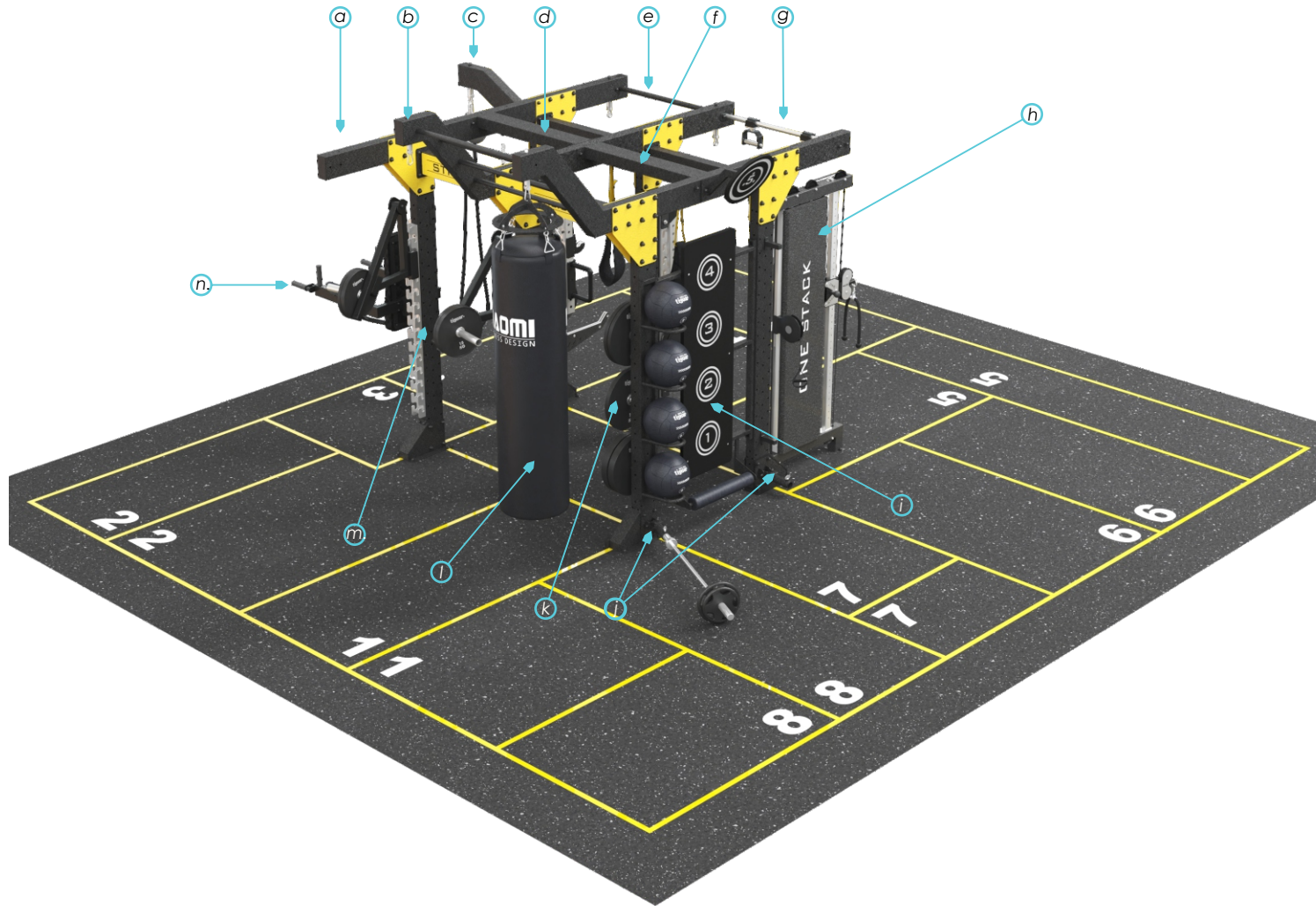

10X TRAINING X200



DETAILS

MODULE LIST:		
a	BASE FRAME	1x
b	CALISTHENICS HIGH	1x
c	ENDLESS ROPE	1x
d	GRIP BALLS	1x
e	PULL UP	1x
f	AB STRAPS	1x
g	PULL UP HANDLES	1x
h	ONE STACK	1x
i	WALL BALL	1x
j	TORSO POINTS	1x
k	PLATE HOLDER	1x
l	BOXING BAG	1X
m.	ARMS	1x
n	DIP - AB-TRON	1X

 www.naomifitnessdesign.com

 sales@naomifitnessdesign.com

 +48 881 912 539

10X TRAINING X200

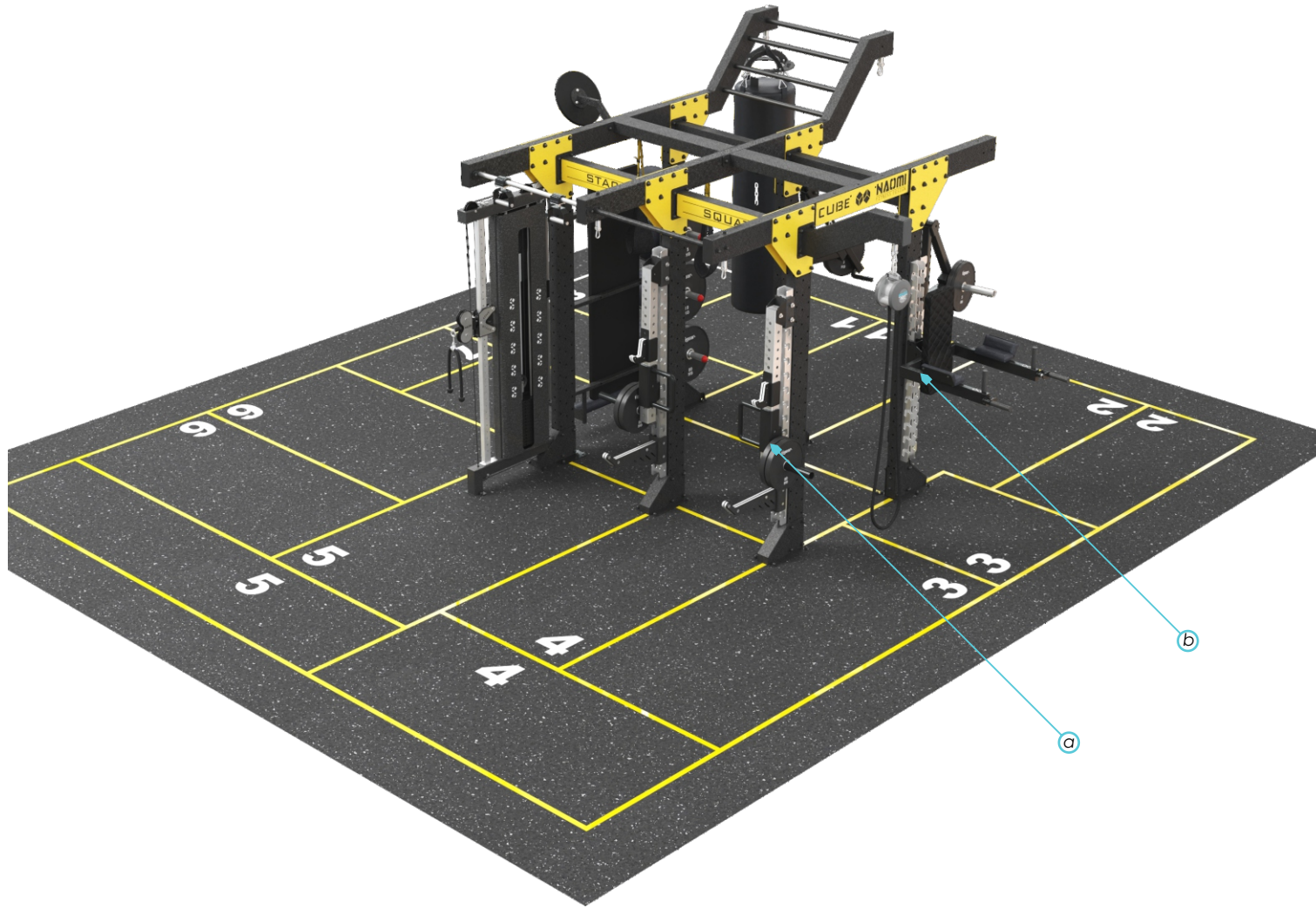

DETAILS

MODULE LIST:		
a	STRENGTH ARMS / SQUAT	1x
b	DIP - AB-TRON	1x

 www.naomifitnessdesign.com

 sales@naomifitnessdesign.com

 +48 881 912 539

10X TRAINING X200 FLOOR

800 cm

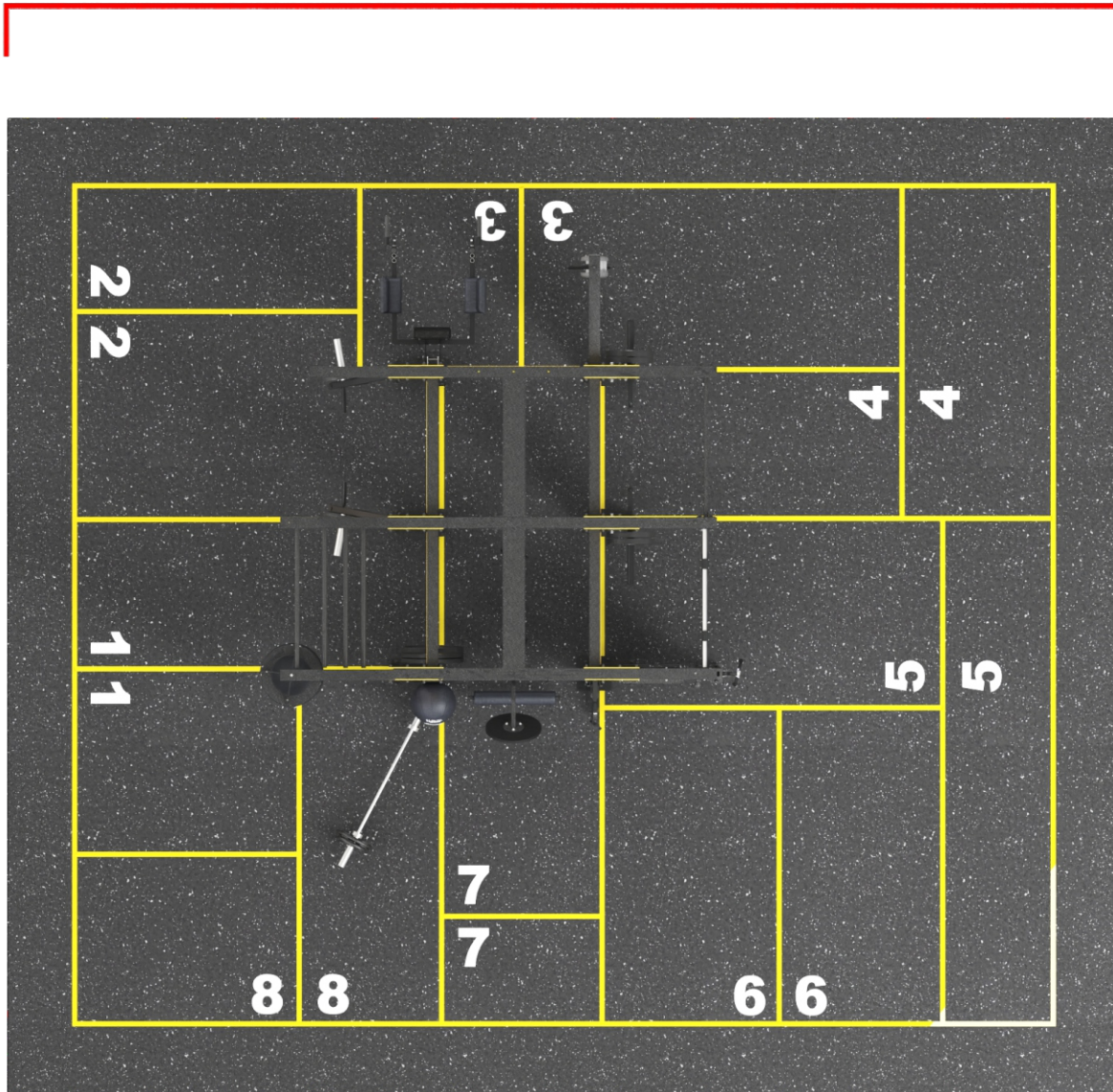

DETAILS

Set of rubber puzzles with maked workout zones 1 - 8

FEATURE LIST:

STANDARD DIMENSION	800 x 700 cm
THICKNESS	20mm